

BTc Controls P2-DC

P2-DC Position Feedback Control



Specifications

Supply Power:	25 Amps max. @ 12 volts 12.5 Amps max. @ 24 volts
Operating Temperature:	-20° F to +150° F (-29° C to 66° C)
Protection:	Zenerdiode suppression on the input and output for protection from electrical noise.

The P2.0 Position Control is a microprocessor position feedback control providing a 0-10 volt DC output indicating actuator travel. The control uses two inductive pulse count sensors and a counting wheel to accurately determine actuator position. A third sensor at the full retract position provides a zero or home position indication.

Hall effect limit switches (those used in the P1.0 control) are used to provide end of travel positioning and will shut off the actuator at both full extend and retract settings. All sensors are non-contact and sealed for life. They are integrated within the actuator and control to protect them from contamination.

Live power is needed to maintain the 0-10VDC analog output signal even when the "Customer Supplied Switch" is not activated. This feature has to be connected to ensure position is saved. The power has to be the same as the switched power supplied to the actuator and requires less than 100mA.

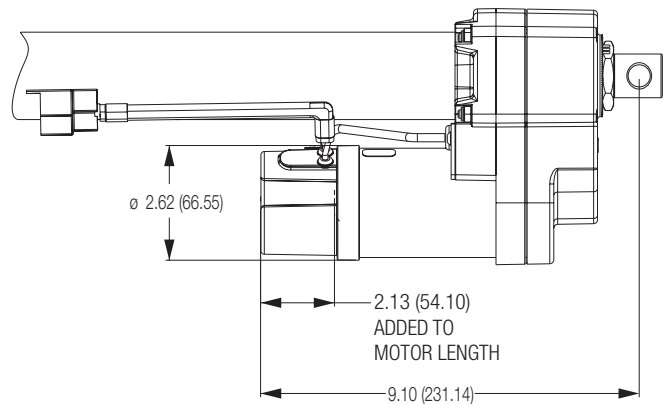

Wiring Diagram

**P2 Module
P2.0-DC12/24**

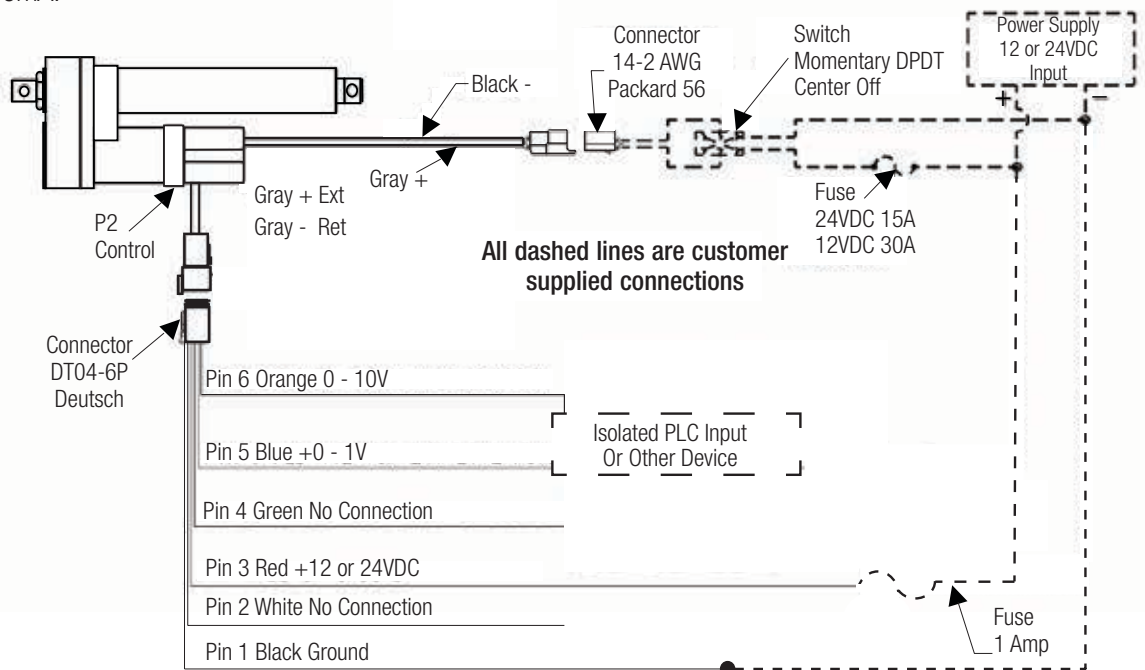

Model Selection

Model No.	Input Voltage (vdc)	Maximum Output Current (Amps)	Features
P2.0 (DC12)	12	25	Base = Electronic Stroke Limits with 0 to + 10V Analog Output and EDB
P2.0 (DC24)	24	12.5	Base = Electronic Stroke Limits with 0 to + 10V Analog Output and EDB